

TRANSLAS [®]
DUTCH TORCH TECHNOLOGY

8XR COBOT MIG EXTRACTOR





8XR COBOT MIG EXTRACTOR

SOURCE EXTRACTION

**COBOT
EXTRACTOR**

8XR COBOT

MADE FOR COBOT AND SEMI-AUTOMATIC SOLUTIONS

Certified By Universal Robots

SAFE & EFFECTIVE EXTRACTION OF WELDING FUMES DIRECTLY AT THE SOURCE.



CLEAN AIR

8XR MIG COBOT EXTRACTOR

The 8XR Cobot MIG Extractor integrates one of the most efficient fume extraction structures in the welding industry. The torch comes with four different angles 22°, 35°, 45° and straight.

The 8XR Cobot MIG Extractor, combined with the ClearO2 W-series 100 and 200, captures up to 98% of welding fumes directly at the source. The 8XR Cobot MIG Extractor provides one of the safest and most effective solutions for welders and workers to breathe CLEAN AIR and better work environments and works with the UR5e, UR10e & UR16e Universal Robot's.



CLEAN AIR









8XR COBOT MIG EXTRACTOR

REDUCES WELDING FUMES UP TO 98%

**COBOT
EXTRACTOR**

FEATURES

-  ROBUST
-  UNIQUE CONTACT TIP FOR MAXIMUM DURABILITY
-  VARIOUS GAS NOZZLES FOR BEST PERFORMANCE
-  DESIGNED FOR ENLARGED ANGULAR MOVEMENT
-  THE SWAN NECK IS SECURED IN TWO PLACES

 PATENTED



HOW DOES IT WORKS?

The 8XR MIG Extractor is specially made for Cobot and Semi-Automatic solutions. The 8XR is robust and the unique nozzle design combined with the ClearO2 W-series 100 and 200 provides the best results in taking away the fumes directly at the source. The specially designed nickel-plated contact tips are designed for a longer lifetime. The contact tips are available for all types of wire and sizes. The 8XR cobot works on the UR5e, UR10e and UR16e Universal Robot's.

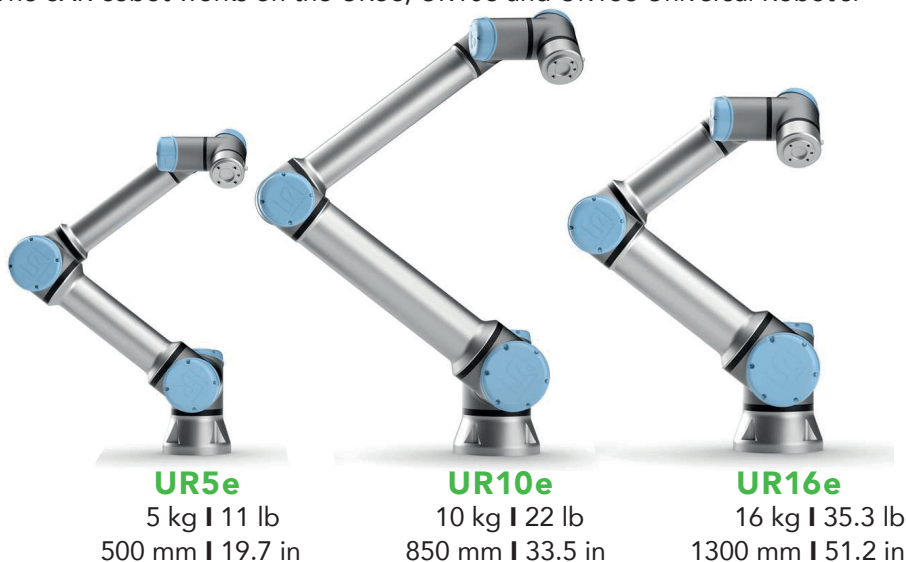

UNIQUE NOZZLE DESIGN FOR OPTIMAL PERFORMANCE AND DURABILITY.

The nozzle design is unique to provide the best results. Openings, wall thickness and grip ribs are thoroughly developed for optimal operation and best performance.

WIRE FEED CONNECTORS

The 8XR MIG Extractor is as standard fitted with a EURO connector and like other Translas MIG lines available to fit any type of machine.

EXTRACTION





8XR COBOT MIG EXTRACTOR LINE

COBOT
EXTRACTOR



8XR MIG COBOT

250

MINI

**AIR
COOLED**

CO₂ - 280 AMP
Mixed Gases - 250 AMP
Duty Cycle - 100%



8XR MIG COBOT

500

**WATER
COOLED**

CO₂ - 550 AMP
Mixed Gases - 500 AMP
Duty Cycle - 100%

EXTRACTION

8XR MINI COBOT MIG EXTRACTOR

CO2 - 280 AMP, MIXED GASES - 250 AMP, DUTY CYCLE - 100%



AIR COOLED

CLEAN AIR

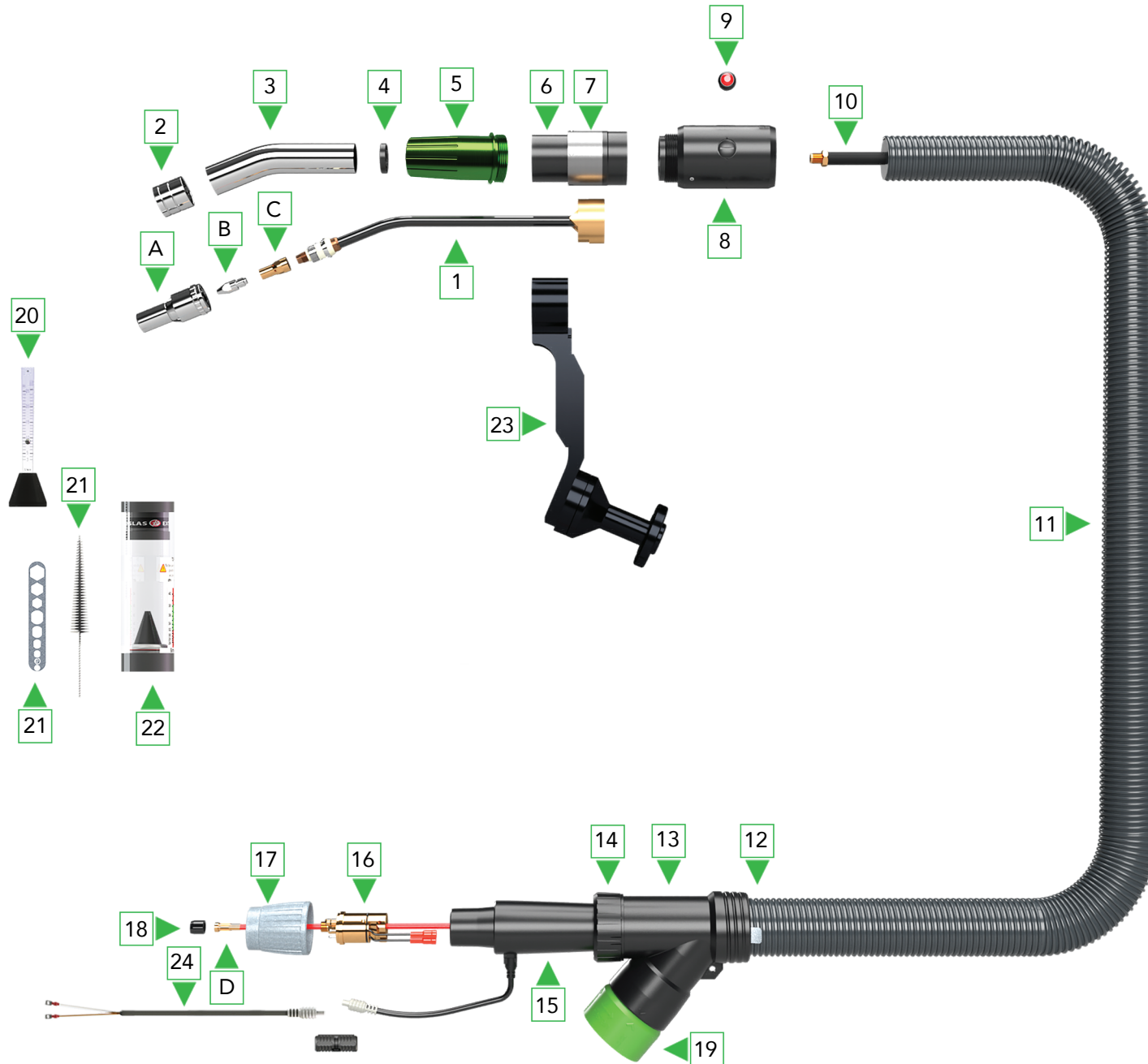

PART NO.	DESCRIPTION	PACK QTY
COMPLETE TORCHES		
Standard with external switch cable (item 24) connected to spring pins		
Standard without torch holder set (item 23)		1
8XR6200201080	8XR Cobot Extractor MINI 2mtr with 22° neck	1
8XR6200301080	8XR Cobot Extractor MINI 3mtr with 22° neck	1
8XR6200401080	8XR Cobot Extractor MINI 4mtr with 22° neck	1
8XR6400201080	8XR Cobot Extractor MINI 2mtr with 45° neck	1
8XR6400301080	8XR Cobot Extractor MINI 3mtr with 45° neck	1
8XR6400401080	8XR Cobot Extractor MINI 4mtr with 45° neck	1
8XR6000201080	8XR Cobot Extractor MINI 2mtr with Straight neck	1
8XR6000301080	8XR Cobot Extractor MINI 3mtr with Straight neck	1
8XR6000401080	8XR Cobot Extractor MINI 4mtr with Straight neck	1
Additional options		
8XR*****90	Execution with Push-button switch connected to springpins (item 9)	
8XR*****91	Execution with Push-button switch connected to external connector (item 9 & 24)	

ITEM	PART NO.	DESCRIPTION	PACK QTY
CONSUMABLES			
A	3937000	Nozzle 8XR/8XE Extractor MINI 12mm	5
	3937001	Nozzle 8XR/8XE Extractor MINI 14mm special	5
	3937002	Nozzle 8XR/8XE Extractor MINI 14mm	5
	3937005	Nozzle 8XR/8XE Extractor MINI 17mm special	5
B	399008	Contact tip 8XR/8XE - 0,8	25
	399010	Contact tip 8XR/8XE - 1,0	25
	399012	Contact tip 8XR/8XE - 1,2	25
	3990102	Contact tip 8XR/8XE - 1,0 Alu	25
	3990122	Contact tip 8XR/8XE - 1,2 Alu	25
	3990101	Contact tip 8XR/8XE - 1,0 CuCrZr	25
	3990121	Contact tip 8XR/8XE - 1,2 CuCrZr	25
C	39327110	8XR/8XE Tip adapter MINI	10
D	301525	Plastic coated liner blue (2,0/4,5) 2mtr -for 0,8mm wire	1
	301535	Plastic coated liner blue (2,0/4,5) 3mtr -for 0,8mm wire	1
	301545	Plastic coated liner blue (2,0/4,5) 4mtr -for 0,8mm wire	1
	302525	Plastic coated liner red (2,0/4,5) 2mtr -for 1,0/1,2mm wire	1
	302535	Plastic coated liner red (2,0/4,5) 3mtr -for 1,0/1,2mm wire	1
	302545	Plastic coated liner red (2,0/4,5) 4mtr -for 1,0/1,2mm wire	1
	304829	Graphite liner black (2,0/4,0) 2mtr combiliner- for 1,0/1,2mm wire	1
	304830	Graphite liner black (2,0/4,0) 3mtr combiliner- for 1,0/1,2mm wire	1
	304831	Graphite liner black (2,0/4,0) 4mtr combiliner- for 1,0/1,2mm wire	1



ITEM	PART NO.	DESCRIPTION	PACK QTY
SPARE PARTS			
1	3980122	8XR Swanneck MINI 22°	1
	3980145	8XR Swanneck MINI 45°	1
	3980100	8XR Swanneck MINI straight	1
	3950005	PEEK ring for 8XR/8XE swanneck MINI (not shown)	5
2	3950100	8XR Nozzle holder MINI	1
3	3980522	8XR Metal neck 22°	1
	39502453	8XR Metal neck 45° (partnumber 3980601 is needed)	1
	3980601	8XR Metal neck connector for 45° neck	1
	3980500	8XR Metal neck straight	1
4	3980490	8XR Centre ring for swanneck MINI	1
5	39804411	8XR Adapter metal neck green	1
6	3980400	8XR Torch body	1
7	3980405	8XR Centre bush	1
	3980410	8XR Centre screw M4 (not shown - 3 pieces is needed)	5
8	3980700	8XR Connection set	1
9	3501575	Push-button switch red	2
10	259262XR	Coax cable 8XR MINI 2mtr	1
	259263XR	Coax cable 8XR MINI 3mtr	1
	259264XR	Coax cable 8XR MINI 4mtr	1
11	3402022	Fume cover hose 8XR/8XE 36-44mm 2mtr	1
	3402032	Fume cover hose 8XR/8XE 36-44mm 3mtr	1
	3402042	Fume cover hose 8XR/8XE 36-44mm 4mtr	1
12	398030	Hose connection	1
13	398100	Housing (Y-shape) for fume extraction hose	1
14	398015	Connection ring	1
15	398010	Housing set for central connector	1
16	305298E23	Central connector Euro air-cooled	1
17	8M9420	Adaptor nut	2
18	305316	Liner positioner nut	10
19	398110	Hose adapter	1
20	406050	Gasflow meter	1
21	371208	Tool set (brush and multitool)	1
22	371350	Airflow meter 8XE/8XR Extractor MINI	1
23	3991022	8XR Torchholder set 22°	1
24	Please ask	Push Button connection (also in combination with item 9)	1

8XR COBOT MIG EXTRACTOR

CO2 - 550 AMP, MIXED GASES - 500 AMP, DUTY CYCLE - 100%



WATER COOLED

CLEAN AIR

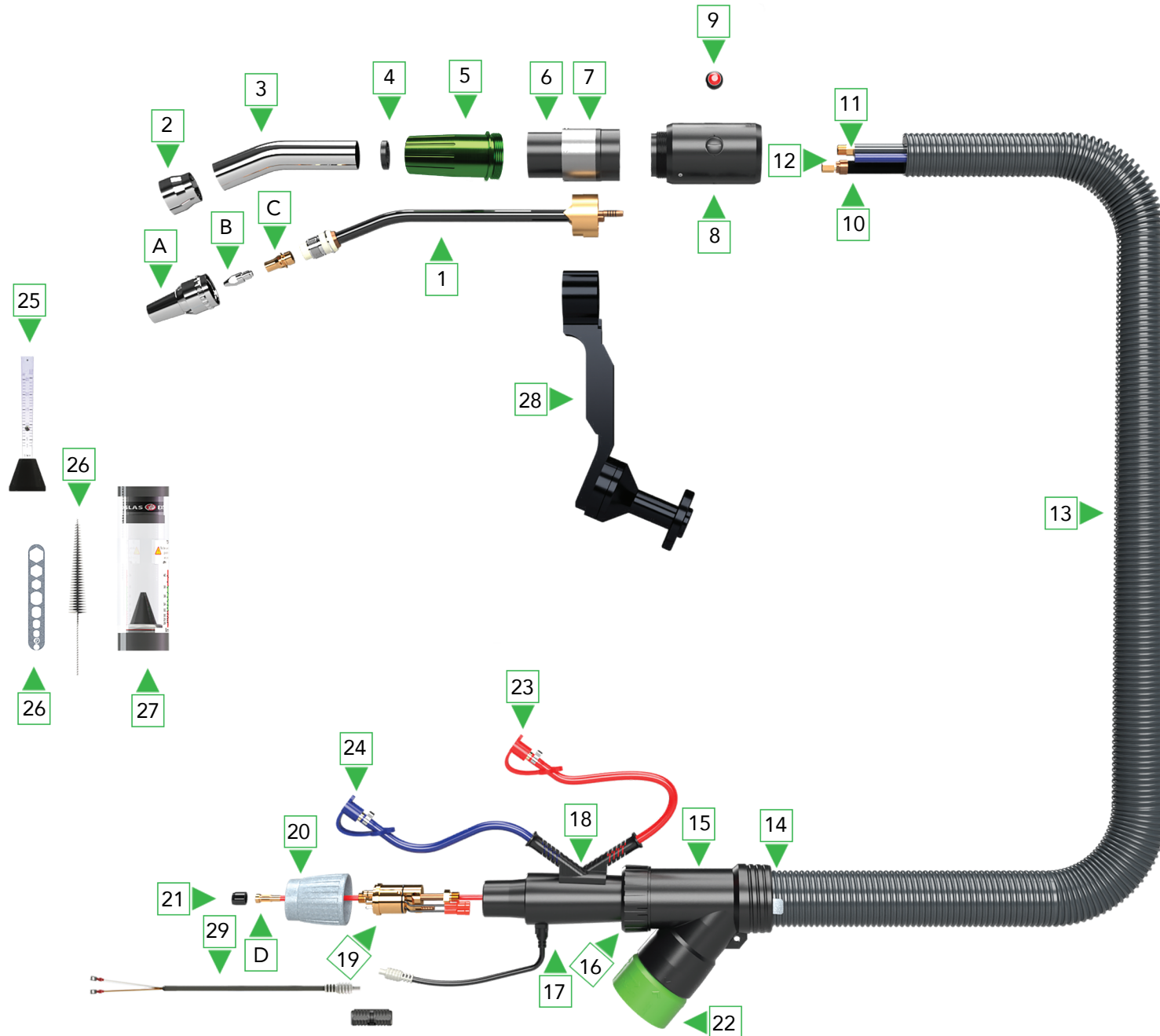

PART NO.	DESCRIPTION	PACK QTY
COMPLETE TORCHES		
	Standard with external switch cable (item 29) connected to spring pins	
	Standard without torch holder set (item 28)	
8XR9260201080	8XR Cobot Extractor water cooled 2mtr with 22° neck	1
8XR9260301080	8XR Cobot Extractor water cooled 3mtr with 22° neck	1
8XR9260401080	8XR Cobot Extractor water cooled 4mtr with 22° neck	1
8XR9460201080	8XR Cobot Extractor water cooled 2mtr with 45° neck	1
8XR9460301080	8XR Cobot Extractor water cooled 3mtr with 45° neck	1
8XR9460401080	8XR Cobot Extractor water cooled 4mtr with 45° neck	1
8XR9060201080	8XR Cobot Extractor water cooled 2mtr with Straight neck	1
8XR9060301080	8XR Cobot Extractor water cooled 3mtr with Straight neck	1
8XR9060401080	8XR Cobot Extractor water cooled 4mtr with Straight neck	1
8XR*****90	Execution with Push-button switch connected to springpins (item 9)	
8XR*****91	Execution with Push-button switch connected to external connector (item 9 & 29)	

ITEM	PART NO.	DESCRIPTION	PACK QTY
CONSUMABLES			
A	3937041	Nozzle 8XR/8XE Extractor 14mm special	5
	3937045	Nozzle 8XR/8XE Extractor 17mm special	5
B	399008	Contact tip 8XR/8XE - 0,8	25
	399010	Contact tip 8XR/8XE - 1,0	25
	399012	Contact tip 8XR/8XE - 1,2	25
	399016	Contact tip 8XR/8XE - 1,6	25
	3990102	Contact tip 8XR/8XE - 1,0 Alu	25
	3990122	Contact tip 8XR/8XE - 1,2 Alu	25
	3990101	Contact tip 8XR/8XE - 1,0 CuCrZr	25
	3990121	Contact tip 8XR/8XE - 1,2 CuCrZr	25
	3990161	Contact tip 8XR/8XE - 1,6 CuCrZr	25
C	39327210	8XR/8XE Tip adapter	10
D	301525	Plastic coated liner blue (2,0/4,5) 2mtr -for 0,8mm wire	1
	301535	Plastic coated liner blue (2,0/4,5) 3mtr -for 0,8mm wire	1
	301545	Plastic coated liner blue (2,0/4,5) 4mtr -for 0,8mm wire	1
	302525	Plastic coated liner red (2,0/4,5) 2mtr -for 1,0/1,2mm wire	1
	302535	Plastic coated liner red (2,0/4,5) 3mtr -for 1,0/1,2mm wire	1
	302545	Plastic coated liner red (2,0/4,5) 4mtr -for 1,0/1,2mm wire	1
	303625	Plastic coated liner yellow (2,4/4,5) 2mtr -for 1,6mm wire	1
	303635	Plastic coated liner yellow (2,4/4,5) 3mtr -for 1,6mm wire	1
	303645	Plastic coated liner yellow (2,4/4,5) 4mtr -for 1,6mm wire	1
	304829	Graphite liner black (2,0/4,0) 2mtr combiliner- for 1,0/1,2mm wire	1
	304830	Graphite liner black (2,0/4,0) 3mtr combiliner- for 1,0/1,2mm wire	1
	304831	Graphite liner black (2,0/4,0) 4mtr combiliner- for 1,0/1,2mm wire	1
	3048341	Graphite liner black (2,3/4,7) 2mtr combiliner- for 1,6mm wire	1
	3048351	Graphite liner black (2,3/4,7) 3mtr combiliner- for 1,6mm wire	1
	3048361	Graphite liner black (2,3/4,7) 4mtr combiliner- for 1,6mm wire	1



ITEM	PART NO.	DESCRIPTION	PACK QTY
SPARE PARTS			
1	3980022	8XR Swanneck water cooled 22°	1
	3980045	8XR Swanneck water cooled 45°	1
	3980000	8XR Swanneck water cooled straight	1
	3950205	PEEK ring for 8XR/8XE swanneck air/water (not shown)	5
2	3950200	Nozzle holder for 8XR/8XE Nozzle	1
3	3980522	8XR Metal neck 22°	1
	39502453	8XR Metal neck 45° (partnumber 3980601 is needed)	1
	3980601	8XR Metal neck connector for 45° neck	1
	3980500	8XR Metal neck straight	1
4	3980480	8XR Centre ring for swanneck	1
5	39804411	8XR Adapter metal neck green	1
6	3980400	8XR Torch body	1
7	3980405	8XR Centre bush	1
	3980410	8XR Centre srew M4 (not shown - 3 pieces is needed)	5
8	3980700	8XR Connection set	1
9	3501575	Push-button switch red	2
10	258512X8R	Power/water cable 8XR/8XE 2mtr	1
	258513X8R	Power/water cable 8XR/8XE 3mtr	1
	258514X8R	Power/water cable 8XR/8XE 4mtr	1
11	2585312XR	Outer liner 8XR/8XE 2mtr	1
	2585313XR	Outer liner 8XR/8XE 3mtr	1
	2585314XR	Outer liner 8XR/8XE 4mtr	1
12	258535	Water inlet hose 5x8mm blue per mtr	100
	258566	Water outlet hose 5x8mm red per mtr	100
13	3402022	Fume cover hose 8XR/8XE 36-44mm 2mtr	1
	3402032	Fume cover hose 8XR/8XE 36-44mm 3mtr	1
	3402042	Fume cover hose 8XR/8XE 36-44mm 4mtr	1
14	398030	Hose connection	1
15	398100	Housing (Y-shape) for fume extraction hose	1
16	398015	Connection ring	1
17	398010	Housing set for central connector	1
18	350881	Water hose guide	1
19	305304E23	Central connector Euro watercooled	1
20	8M9420	Adaptor nut	2
21	305316	Liner positioner nut	10
22	398110	Hose adapter	1
23	258701	Waterstop red	10
24	258702	Waterstop blue	10
25	406050	Gasflow meter	1
26	371208	Tool set (brush and multitool)	1
27	371300	Airflow meter 8XE/8XR Extractor	1
28	3991022	8XR Torchholder set 22°	1
29	Please ask	Push Button connection (also in combination with item 9)	1



EXTRACTION



8XR COBOT MIG EXTRACTOR

CONSUMABLES TO FIT YOUR SPECIFIC WELDING APPLICATION

**COBOT
EXTRACTOR**

The specially designed nickel-plated contact tips for the complete 8XR Cobot & 8XE MIG Extractor series are designed for a longer lifetime.

You can choose from:

- Standard copper for everyday welding.
- Available in sizes from .030" (0.8mm) - .095" (2.4mm.)
- Special tips for aluminum welding.

CONTACT TIPS



WIRE FEED CONNECTORS

EURO CONNECTOR

There are wire feed connectors available to fit any type of machine. Due to the design of the backend housing, you can switch between the connector types with ease.



MAINTENANCE

AIRFLOW METER

Always use the Airflow meter to ensure maximum extraction effect.

GAS METER

The gas meter is used for best weld quality by keeping the right amount of shielding gas around the weld seam.

CERAMIC SPRAY

Prolong the life of your gun and all spare parts by applying the ceramic spray to the 8XE and 8XR Extractor before work.



FREE DRIVE BUTTON

NOZZLE OPTIONS

There are different nozzle variations to suit any kind of joint application and deliver best welding results. The nozzles can be changed in a second.

8XR & 8XE REGULAR

14mm-Special

Where space is limited and fit is tight, this nozzle offers better access and more excellent shielding gas coverage to prevent porosity. This 14mm special nozzle is delivered as a standard on every extractor torch.



8XR & 8XE REGULAR

17mm-Special

For heavier-thickness, high-current and high-deposition butt and lap joint applications, this nozzle offers more excellent shielding gas coverage to prevent porosity.



LINERS

Choose the right liner for your wire diameter and type when working with a 8XE & 8XR Extractor Torch:

Blue: (1.5/4.5) Up to 5mtr

Red: (2.0/4.5) Up to 5mtr

Yellow: (2.5/4.5) Up to 5mtr

All liner types are suitable for stainless steel applications. For Aluminium application, there are the following types:

Blue , Red and Yellow in Teflon and Graphite.

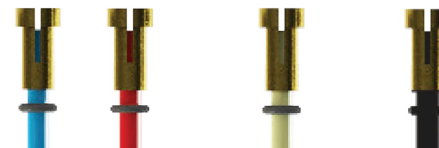

EXTRACTION

Demo Request

Scan the QR code with your smart phone



▶ BY WELDERS. FOR WELDERS



+31 (0)30 - 604 73 73



Fahrenheitbaan 2
3439 MD Nieuwegein
The Netherlands



info@translas.com

www.translas.com

EUROPE

UNITED KINGDOM

NORTH AMERICA

